

MANUAL

SERIES: SD 1525



SERVO DYNAMICS

21541 D Nordhoff St., Chatsworth, CA 91311
(818) 700-8600 • FAX (818) 718-6719

This is a general manual describing a series of amplifiers. Please be sure to refer to the installation drawing and information supplied with the particular unit for proper electrical connections.

CAUTION

THE ELECTRICAL CONNECTIONS AND ADJUSTMENTS PROVIDED HEREIN SHOULD BE ATTEMPTED ONLY BY A SKILLED TECHNICIAN USING PROPER EQUIPMENT SO AS TO NOT VOID YOUR WARRANTY.

WARRANTY PROVISION CLAUSE

WARRANTY - The Seller warrants that the articles to be delivered under this purchase order will be free from defects in material and workmanship under normal use and are limited to replacing or repairing, at its option, at its factory, any of said articles which within one (1) year after shipment be returned to the Seller's factory of origin, transportation charges prepaid, and which are, after examination, disclosed to the Seller's satisfaction to be thus defective. **THIS WARRANTY IS EXPRESSED IN LIEU OF ALL OTHER WARRANTIES, EXPRESSED OR IMPLIED, INCLUDING THE IMPLIED WARRANTY OF FITNESS FOR A PARTICULAR PURPOSE, AND OF ALL OTHER OBLIGATIONS OR LIABILITIES ON THE SELLER'S PART AND IT NEITHER ASSUMES NOR AUTHORIZES ANY OTHER PERSON TO ASSUME FOR THE SELLER ANY OTHER LIABILITIES IN CONNECTION WITH THE SALE OF THE SAID ARTICLES.**

This warranty shall not apply to any of such articles which shall have been subjected to misuse, negligence, or accident. The aforementioned provisions do not extend the original warranty period of any article which has either been repaired or replaced by Seller.

TABLE OF CONTENTS

<u>SECTION</u>	<u>PAGE</u>
FOREWARD	3
SPECIFICATIONS	4
DIMENSIONS	4
BLOCK DIAGRAM (FIG. 1)	5
DISCUSSION OF BLOCK DIAGRAM	6
SIMPLIFIED BOARD LAYOUT (FIG. 2)	7
CONNECTOR INFORMATION	8 - 11
TEST POINT INFORMATION	11
PROTECTION	12
ADJUSTMENTS	13
INSTALLATION DRAWING	14 A & B
INSTALLATION INSTRUCTIONS	15
SIMPLIFIED SYSTEM SET UP	16 - 18
SYSTEM COMPENSATION WITH OSCILLOSCOPE	19
TACH PICTORIAL SECTION (FIG. 3A & 3B)	20 A & B
MODIFIED COMPENSATION	21
TROUBLE SHOOTING	22
SHUNT REGULATOR	23
BOARD LAYOUT (FIG. 4)	24
POTENTIOMETER SETTINGS	25
SUMMING AMPLIFIER SCHEMATIC	26
SIMPLIFIED AMPLIFIER SCHEMATIC	27
APPENDIX	28

FOREWARD

This manual is a general purpose manual describing the theory of operation, product specification, installation instructions and adjustment procedure, for the SD 1525 PWM Servo Amplifier Series.

The Servo Amplifier described herein is a Pulse Width Modulated (PWM) type used for controlling a DC brush type servo motor.

A complete chassis assembly consists of one or more amplifier modules (SD 1525) mounted on a sub panel, containing a + 15 volt supply, bus rectifier, filter capacitor, fans and associated wiring.

SPECIFICATIONS: Model 1525-10

Peak Voltage ± 100 VDC
 Peak Current (see note 1) ± 25 Amps
 Continuous Voltage(typ) ± 92 VDC
 Continuous Current(see note 2) ± 15 Amps
 Horsepower(Cont) 1.85 HP
 Input Power Req. Bus.+30 to +100VDC (nom)
 Bias +15VDC (350 ma min.)
 -15VDC (60 ma min.)
 Signal Input Voltages ± 10 Volts(typ)
 ± 35 Volts(max)
 Signal Inputs(adj)
 1)Aux Single Ended
 2)Signal Diff. or Single Ended
 3)Tach Single Ended
 Gain 0 to 6000 amps/volts
 Signal Input Impedance 20K min.
 Signal Balance Adj.
 Drift(refer to input) $10 \mu V/^\circ C$
 Switching Freq. 5 KHZ
 Bandwidth 1.5 KHZ
 Current Limit(adj) 0 to 25 amps
 RMS limit(adj) 5 to 15 amps

Protection with LED Indication(see note3)

LED 1 Overvoltage
 Undervoltage
 LED 2 Motor ground faults
 LED 3 Over temperature
 Excessive RMS current
 LED 4 Excessive transistor current
 Shorted motor output

System Compensation Adj.
 Ambient Temp.(oper.) 0 to 50°C
 Auxiliary Inputs Gain reduction
 Limit switch over-travel(N.O.orN.C.)
 Remote on-off
 Programmable current limit
 Remote reset
 Auxilliary Outputs Load current monitor
 + 15 volts
 Options Special compensation
 Internal reset
 Current foldback-no shut off

Notes:

1. Maximum peak current is available for 1 second
2. The amplifier has a built-in RMS protection circuit. If the continuous current level is exceeded for an extended time the amplifier will trip-off and stay off with LED indication.
3. The amplifier when tripped will stay off with LED indication.
4. Buffered output can drive a 5K or greater load. 12 volts = 25 amps.
5. Minimum load inductance must be 2.4 mHy, for safe operation.

MODEL	DESCRIPTION	SIZE [INCHES]		
		LENGTH	WIDTH	HEIGHT
SD 1525	MODULE ONLY	8.5	2	6.4
SD1-1525	1 AXIS	10.5	5	7.25
SD2-1525	2 AXIS	10.5	9.25	7.25
SD4-1525	4 AXIS	10.5	13	7.25
SD6-1525	6 AXIS	10.5	17	7.25

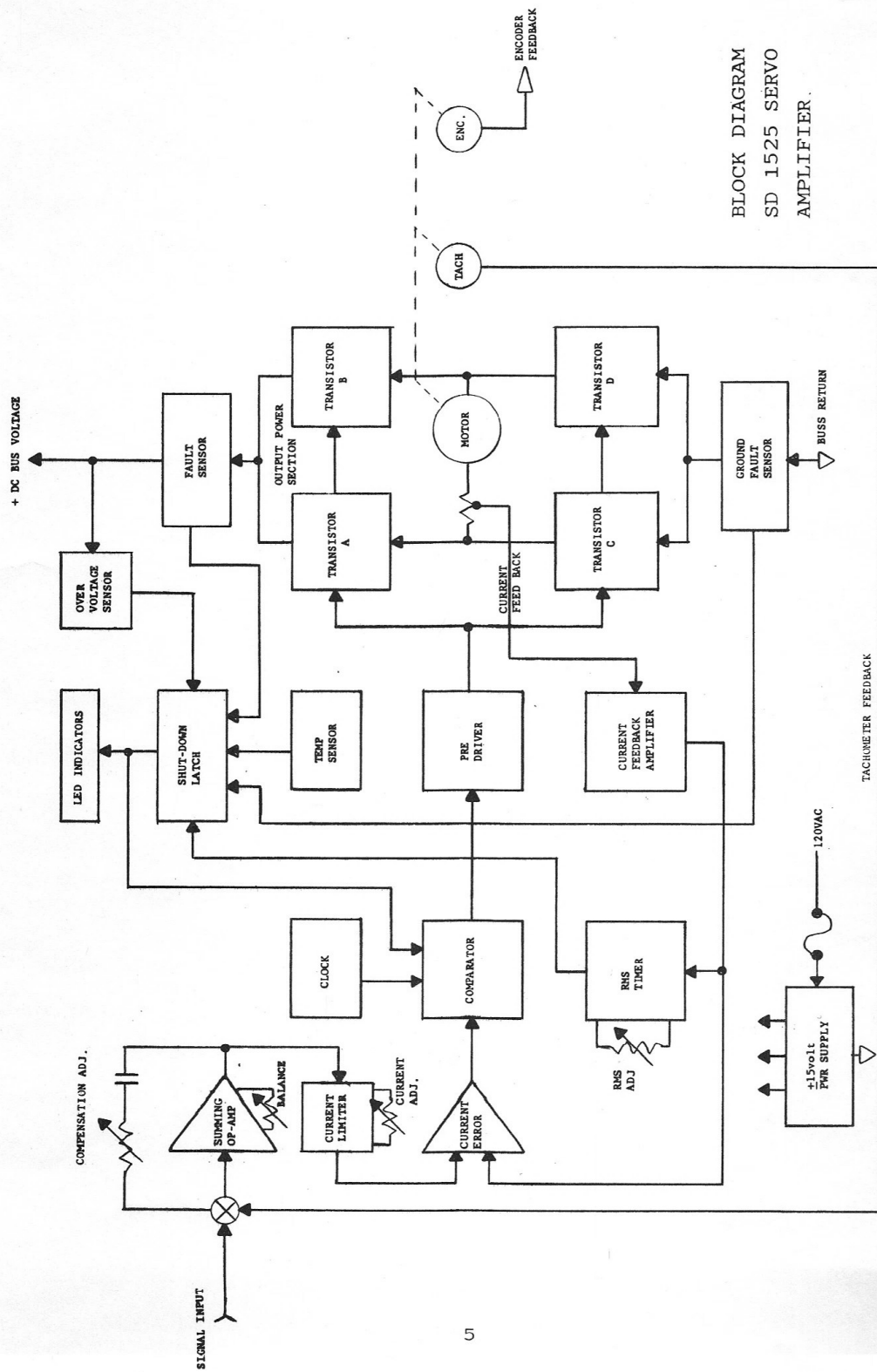

BLOCK DIAGRAM
SD 1525 SERVO
AMPLIFIER.

FIG. 1

DISCUSSION OF BLOCK DIAGRAM

The SD 1525 is a current source pulse width modulated DC Servo Amplifier.

The signals or commands into the amplifier begin at the left hand side of the diagram, marked signal input. A summation of the command and tachometer take place at the summing junction. The difference is fed to the summing op-amp where the signal is amplified and conditioned for optimum system performance.

The signal is then scaled by the current limiter and summed with current feedback at the current error amplifier. The difference is conditioned, amplified and injected with a clock signal, which sets the switching frequency of the amplifier. The comparator either outputs a positive or negative command to the predrivers, at the clock frequency. The predrivers in turn supply the power to turn on the output power section, to the desired current level.

The output power section is protected by various fault protection circuits. These fault circuits provide information to the shut-down latch. If a fault occurs, the predrivers are shut-off immediately and in turn the output power section is shut-down.

The output section is protected from the following fault conditions: Internal bridge faults, over temperature, over voltage, under voltage, excessive load current (RMS TIMER) and motor to chassis grounds.

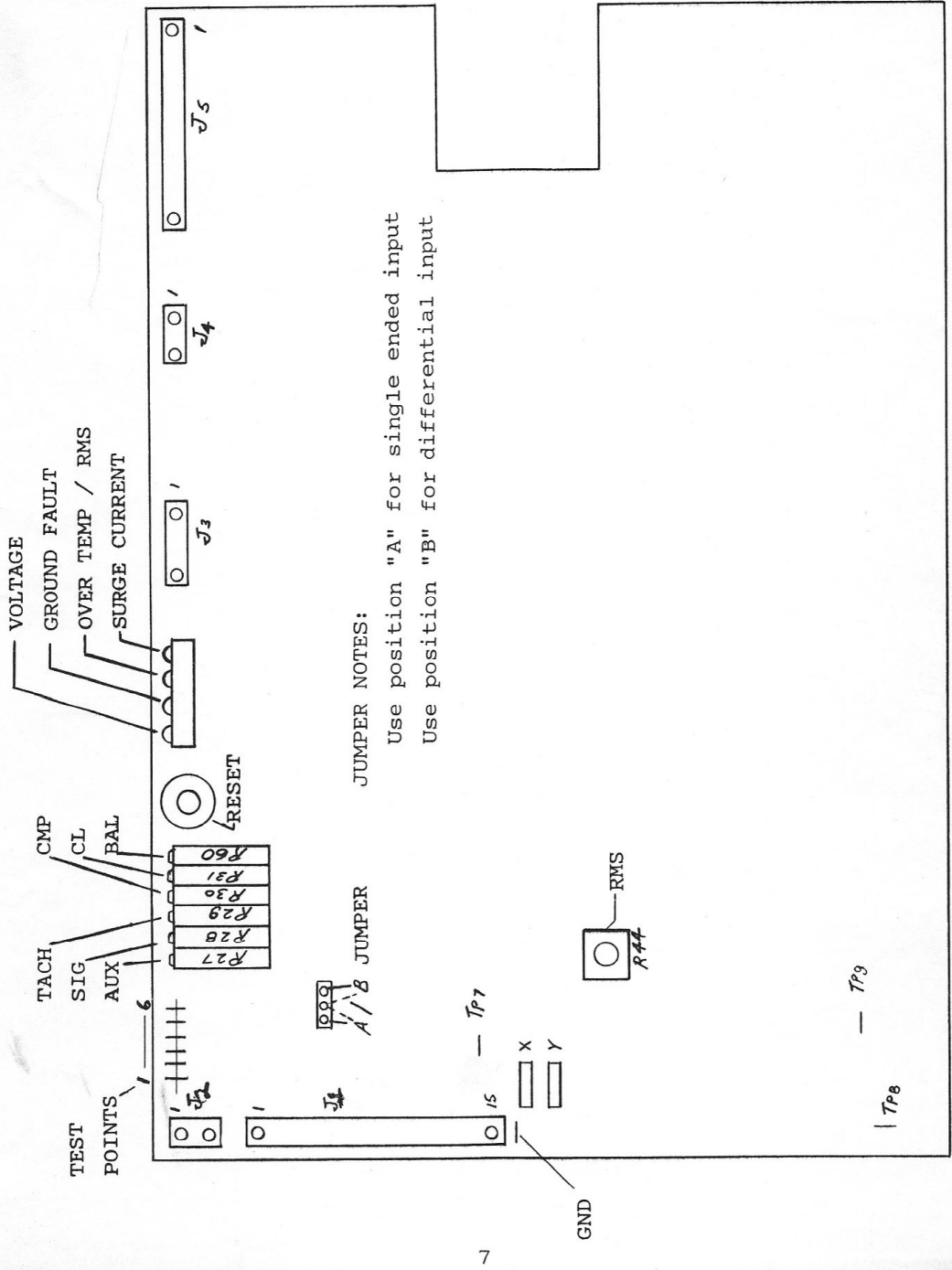

JUMPER NOTES:
 Use position "A" for single ended input
 Use position "B" for differential input

FIG. 2

CONNECTOR INFORMATION

J 1

- PIN 1 - Auxilliary Signal Input - Used as a second signal input - single ended.
- PIN 2 - Standard Signal Input - Used as the main signal input - single ended.
- PIN 3 - Tach Input - Used for Tach input only. This input has additional tach filtering and conditioning - single ended.
- PIN 4 - Signal Common - Used as common when PINS 1, 2, and 3 of J1 are used as inputs.
- PIN 5 - Output Current Monitor - Buffered current monitoring pin. 12 Volts = 25 Amps to the load. Capable of driving a meter or a load greater than 5K, use PIN 9 of J1 as common.
- PINS 6 & 7 - Limit switch overtravel - Normally open.

These PINS are used to inhibit the amplifiers output, and prevent the motor from turning either CW or CCW.

By grounding PIN 6, inhibits one direction of output and PIN 7 inhibits the other direction.
- PIN 8 - Remote Shut Down / Fault condition status output.

The amplifiers output can be totally shutdown externally by pulling this PIN to ground.

This PIN will also go to ground during a fault condition.
- PIN 9 - Power supply common and ground.
- PIN 10 - +15 VDC Approximately 50 MA available for external use.
- PIN 11 - Power supply common and ground.
- PIN 12 - -15 VDC. Approximately 50 MA available for external use.
- PIN 13 - Remote Reset.

This input can be used to reset the amplifier when it has tripped off due to a fault condition. To reset, momentarily pull PIN 13 to ground at PIN 9 or 11 of J1.

Note 1: The resetting of the amplifier is complete, with a one second delay, when PIN 13 is released from ground. This sequence of resetting is such that if PIN 13 is kept low, the safety circuits can not be overridden.

Note 2: If a Fault Condition is still present after reset, the amplifier will not restart.

PINS 14 & 15 - Limit switch overtravel - normally closed.

These PINS are provided for use with normally closed limit switches - (OSHA STANDARD).

These PINS provide the same function as PINS 6 & 7 of J1.

Note: PINS 14 & 15 are shipped from the factory jumpered to ground on the printed ckt board. To utilize these PINS it is necessary to cut the wire links (that look like resistors) marked X and Y located just below and to the right of PIN 15 of J1.

J 2 DIFFERENTIAL INPUT

PIN 1 - Inverting signal Used as a part of the differential input. A positive signal provides a negative signal to the main velocity control op-amp. Used in conjunction with J2 PIN 2.

PIN 2 - Non inverting signal. Normally used as the other half of the differential input. A positive signal provides a positive signal to the main velocity control op-amp. Used in conjunction with J2 PIN 1.

Notes: The amplifiers are normally shipped for single ended jumper operation for inputs J1 PIN 2. Located on the ckt board is a jumper selector (A/B), which when in the "A" position allows for single ended operation. It is necessary to put the jumper in the "B" position for differential operation - see simplified board layout section for location of this jumper.

A/B JUMPER

Used for changing the circuit board input from single ended to differential.

Position "A" Single ended input operation.
Position "B" Differential input operation.

See simplified board layout section for location.

J 3

PIN 1 &
PIN 2 - May be connected together to reduce gain of the velocity control amplifier (A1-B) when PINS 1 and 2 of J3 are connected together. The gain of the amplifier can be adjusted from 0 to 7.8 Amps/Volt.

PIN 1 &
PIN 3 - Can be used to externally program the current limit.

Note: Care must be taken here with proper signal shielding. A noisy signal can damage the output PWR section of the amplifier.

PIN 4 - Normally not used. The purpose of this additional PIN is to distinguish this connector from connector J4.

This PIN could be used as another signal input however, an appropriate input resistor must be installed external to the amplifier.

J 4

PIN 1 - +15 Volt input from Bias Power Supply.

PIN 2 - Bias Power Supply Common.

PIN 3 - -15 Volt Input from Bias Power Supply.

J 5

- PINS 1
& 2 - + Bus Power Input.
+ 30 to +100 VDC Input.
- PINS 4
& 5 - Bus Power Return
- PINS 7
& 8 - Output Power
to DC Motor Armature.
- PINS 10
& 11 - Output Power
to DC Motor Armature.

TEST POINT INFORMATION

- TP1 - Common
- TP2 - Auxillary Input Pot. Wiper
- TP3 - Signal Input Pot. Wiper
- TP4 - Tach. Input Pot. Wiper
- TP5 - Compensation Pot. Wiper

Note: More Discussion will take place about TP1-5
in compensation section.

- TP6 - Tachometer Signal - Directly from J1 PIN 3,
with no resistor divider.
- TP7 - Current Feedback from current feedback
amplifier.
- TP8 - Low Bus Monitor
- TP9 - Clock Output

PROTECTION: REF: FIG. 2 FOR LED LOCATION

The model SD1525-10 is protected against several fault conditions and these are as follows:

Note: When an LED is on. The amplifier has shut-off and will remain off until reset.

Voltage - This LED will give an indication for these conditions.

- 1] Bus voltage has exceeded 130 VDC this condition can exist if:
 - a) The shunt regulator fuses are blown.
 - b) A regulator is required to handle regenerative motor energy, while decelerating, due to excessively high inertia.
- 2] The sum of the \pm 15 Volt Bias supply is less than 28 Volts DC. This condition can exist if a line transient causes the bias supply to dip momentarily or the bias supply has failed. Check bias supply fuse.

GROUND FAULT - This LED will give an indication if one of the output wires to the motor is shorted to ground.

This condition can exist due to:

- a] Faulty or pinched wiring.
- b] Motor arcing to case ground.

OVER TEMP/RMS - This LED provides indication for these conditions.

Overtemperature of the heatsink - the sensor is set to trip at 75-80°C.

A couple of reasons as to why the overtemperature condition might exist.

- a] Clogged or dirty cooling fans.
- b] Insufficient air flow across heatsink
- c] Ambient temperature too high

RMS - Excessive RMS means the amplifier was required to deliver peak current for a period to long and beyond its continuous capability.

This condition can exist if a machine is asked to perform a task greater than it was designed for.

If a motor is mechanically stalled or binding.
If a motor has a shorted armature.

SURGE CURRENT - This LED provides indication for an excessive amount of current thru the power transistors in the output bridge.

Figure 2 shows the location of various components on the main circuit board.

- AUX. - The auxiliary pot. [R27] is used to set the auxiliary signal gain level. Turning R27 "CW" increases the amount of signal into the amplifier.
- SIG. - The signal pot. [R28] is used for the command signal. Turning R28 "CW" increases the amount of signal into the amplifier.
- TACH. - The tach. pot. [R29] is used for the tach. input. This input should be used as the tach. input because of special signal conditioning. Turning R29 "CW" increases the amount of tach-feedback into the amplifier.
- CMP - The CMP (compensation) pot. [R30] is used to increase or decrease the response (bandwidth) of the amplifier. Turning R30 "CW" increases the response of the amplifier.
- CL. - The current limit pot. [R31] is used to set the peak current. Turning R31 "CW" increases the output current, to the motor, from zero amps to 25 amps.
- BAL. - The balance pot. [R60] is used to adjust internal offsets in the amplifier. The function of this pot is such that for zero input volts the output should be at zero amps.
- RMS - This pot. [R44] is for changing the level of the RMS current limiter. The amplifier is capable of providing maximum RMS current when R44 is fully "CW" and minimum current when R44 is fully "CCW." For model 1525-10 the maximum current is 15 amps, the minimum current is 5 amps.

A/B JUMPER

2 POSITION JUMPER

- Position A - For single ended input, apply the command signal to J1 PIN 2 with respect to signal common J1 PIN 4. The A/B Jumper must be in the left position, which is position "A".
- Position B - For differential input, apply the command signal to J2 PIN 1 with respect to J2 PIN 2. The A/B Jumper must be in the right position, which is position "B".

RESET SWITCH

Located on the main circuit board is a reset switch, which is used to reset the amplifier if the amplifier has tripped-off due to a fault condition.

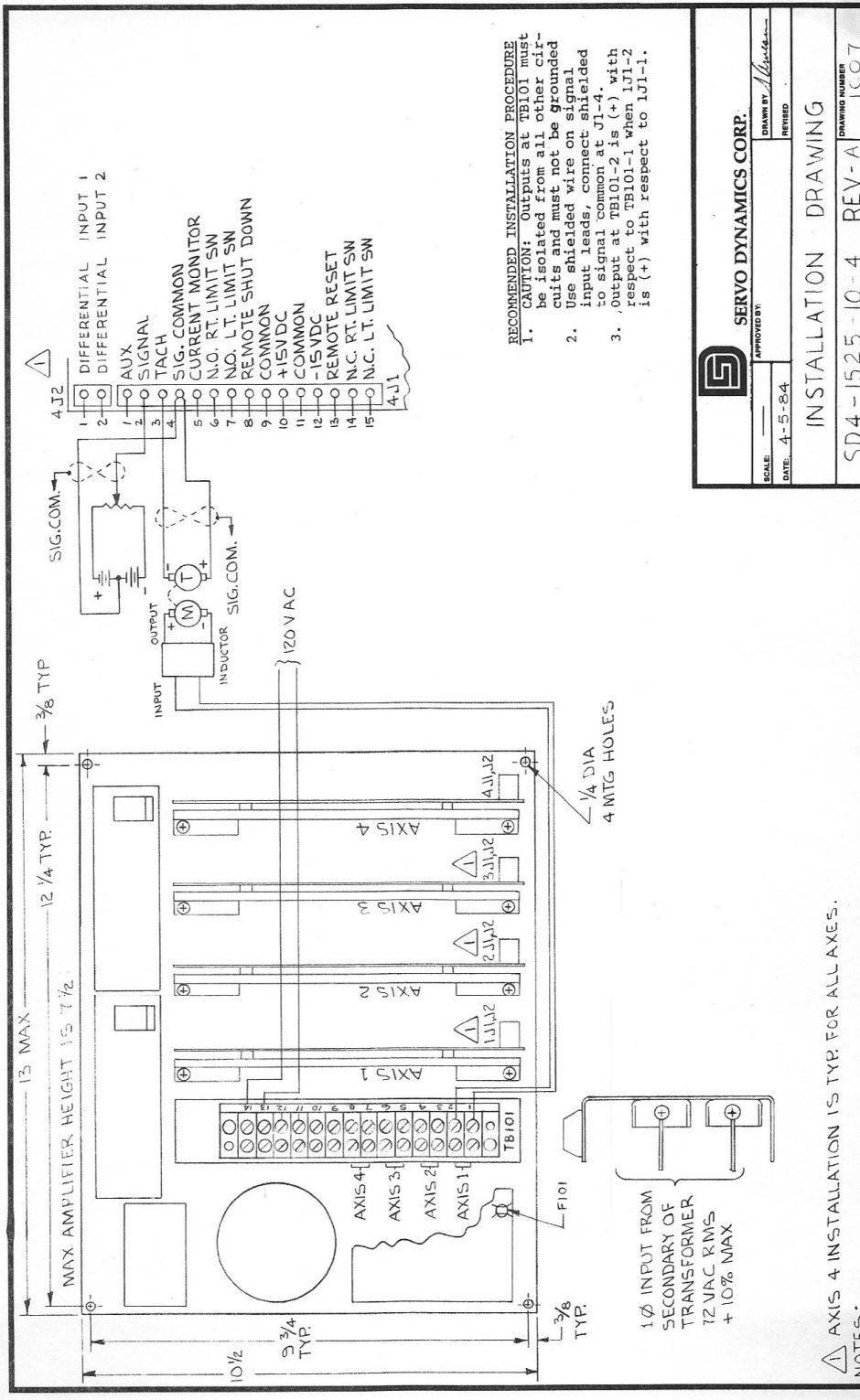

RECOMMENDED INSTALLATION PROCEDURE

1. CAUTION: Outputs at TB101 must be isolated from all other circuits and must not be grounded. Use shielded wire on signal input leads, connect shielded to signal common at J1-4.
2. Output at TB101-1 when IJ1-2 is (+) with respect to IJ1-1.
3. Output at TB101-2 is (+) with respect to IJ1-1.

SERVO DYNAMICS CORP.

APPROVED BY: *[Signature]*

SCALE: 4-5-84

DATE: 4-5-84

REVISION

INSTALLATION DRAWING

SD4-1525-10-4 REV-A

DRAWING NUMBER 1007

△ AXIS 4 INSTALLATION IS TYP. FOR ALL AXES.

NOTES:

INSTALLATION

The amplifiers are supplied with their own specific installation drawing. It is important that one follows the instructions for proper connection of input power, fan power, input signals, tachometer input and motor outputs.

The amplifier should be installed in a location which is suitable for electronic equipment.

The maximum ambient temperature should not exceed 50°C, otherwise nuisance over-temperature tripping may occur.

Make sure there is adequate space around the amplifier and in the cabinet to allow for proper air flow.

BEFORE CONNECTING THE INPUT POWER TO THE AMPLIFIER PLEASE MEASURE THE INPUT POWER VOLTAGE.

One transformer can supply the needs of several amplifier modules provided it is of the proper size and KVA Rating.

Some transformers have dual primaries, please check that the proper input taps and jumpers are installed correctly.

Typically the output voltage of the main power transformer at the secondary can range from 25 VAC to 72 VAC. This voltage when rectified on the amplifier chassis becomes the + Bus Voltage of approximately 100 VDC.

115-125 VAC 2 Amp power is required for the Bias \pm 15V power supply and cooling fans.

The signal input (single ended) is applied to PIN 2 of J1 with respect to signal common PIN 4 of J1.

It is recommended that the tachometer be connected to PIN 3 of J1 w.r.t. signal common PIN 4 of J1.

Use shielded wire on signal and tachometer inputs to the amplifier.

If the motor inductance is less than the recommended minimum - (see spec. sheet). An external inductor must be used.

APPLICATION NOTE:

It is suggested that an external inductor be used mainly in case of a motor winding partially or intermittently shorting out, there is a possibility of damage to the output transistors due to excessive internal heating.

CAUTION

When using test equipment on the amplifier, make sure that it is not grounded. Three pin power cords are grounded, make sure to use an adaptor.

Also make sure you do not ground the output bridge section of the amplifier. The outputs of the amplifier at rest, are 50 VDC above ground.

SIMPLIFIED SYSTEM "SET UP"

Setting up the "Servo Dynamics Amplifier" can be done easily.

The amplifier has conveniently located potentiometers along the top edge of the circuit board.

- 1] Check to be sure all transformer jumpers are correct and the transformers are wired for proper input voltages.
- 2] Verify all input voltages before connecting them to the amplifier.
- 3] Be sure the amplifier is connected per the installation drawing.
- 4] Before applying power
Make sure there is sufficient travel for the machine in case of an emergency.

PRESET THE POTS. AS FOLLOWS

Note: The adjustment pots. are normally 20 turn pots. with the exception of the RMS pot. which is a 1 turn pot.

- AUX. POT. - Fully CCW if not used.
 - SIG. POT. - Mid range [10 Turns].
 - TACH. POT. - Turn fully CCW then 5 turns CW.
 - CMP. POT. - (Compensation) Turn fully CCW then 10 turns CW.
 - CL. POT. - (Current Limit) Turn fully CCW.
 - BALANCE POT. - Leave alone for now.
- 5] Apply power, but do not apply a signal to the amplifier.
 - 6] To check tach. phasing, slowly turn the current limit pot. CW and observe the machine or motor shaft. If the phasing is correct, the motor will stay at rest or move very slowly. If phasing is incorrect the machine will move out of control and try to run away. Turn-off power and reverse the motor or tach. leads.
 - 7] Turn power back on and observe the system is now under control.

Note: If the motor shaft continues to rotate slowly as the current limit pot. is increased, there may be an offset problem which can be taken care of by the Balance Pot. You may adjust the balance pot, now if you desire.

- 8] For the RMS range of current set the RMS pot. (R44) for the desired level of RMS Limiting. Fully CCW is minimum RMS current limiting. Fully CW is maximum RMS current limiting. See specification sheet for your particular amplifier.
- 9] Now set the peak current limit pot R31 for the desired peak current.

R 31 TYPICAL 20 TURN POT. SETTINGS

- 3 Turns CW = 30% peak current
- 6 Turns CW = 60% peak current
- 10 Turns CW = 85% peak current
- 14 Turns CW = 95% peak current

- 10] Turn the CMP (compensation) pot R30 CW until the motor shaft starts to oscillate at a high frequency rate, then turn the CMP pot CCW until the oscillation stops -- then turn $1\frac{1}{2}$ turns CCW for some additional safety margin.

Note 1. Sometimes a system may not break into a high frequency oscillation when the CMP pot is fully clockwise, this is normal since the particular system the amplifier is connected to may have a very high mechanical resonance and the maximum range of the bandwidth of the amplifier is such that the resonance is not reached.

Note 2. Sometimes a system may continue to oscillate at a high frequency even if the CMP pot is fully CCW see notes in "System Compensation Using An Oscilloscope".

- 11] Now apply a small step signal to the amplifiers signal input and watch the motor shaft.

Does the motor shaft overshoot (under damped) when commanded to stop?

Does the motor shaft stop slowly (over damped) when commanded to stop?

Note: The observation of the motor shaft or machine for the way it starts or stops is done at the time just before the motor shaft or machine stops -- not while the motor is accelerating or decelerating the machine.

- 12] Turn the tach pot. CCW for getting rid of over shoots.
Turn the tach pot. CW for making the system settle quicker.

Note: As a general rule it is advisable not to turn the tach. pot. beyond mid-position.

- 13] After the proper closed loop response is obtained then do not adjust the tach pot any more.

- 14] Run the system at high speed and listen to it.

Does it run rough? If so turn "CMP" pot. a little CCW.

- 15] Adjust the signal pot. for desired machine speed -- not the tach pot.

For example: A 10 volt input signal may be required to run the machine at 200 inches per minute.

- 16] It may be necessary to readjust the balance pot for zero drift.

- 17] No further adjustments are necessary.

- 18] Now that you have successfully set up this axis. Lets make your adjustments a lot easier for other amplifiers.

- 19] Shut off the power.

- 20] Disconnect the signal input plug at J1 and/or J2.

- 21] Using a resistance meter, set on the 20K OHMS Scale, connect one end of the meter on TP1 which is common and measure the resistance between test points TP2 thru TP5 and record these values in the back of this manual, for future adjustments. Install J1 and/or J2 and apply power.

SYSTEM COMPENSATION USING AN OSCILLOSCOPE REF: FIG. 3

- 1] Go thru steps 1 thru 10 on simplified system set up procedure.
- 2] Apply a small step input signal and watch the tach. output on an oscilloscope, observe just before the motor stops.

Refer to the "Tach. Pictorial Section".

- 3] If the tach.-loop is over damped turn the tach. pot. CW until you observe the desired results.

NOTE: Do not turn the tach. pot. any further CW (in step 3) than necessary. If you turn the tach. pot. to far "CW" the system will run rough because of excessive bandwidth and you will work the motor-amplifier combination harder than necessary.

- 4] If you are having trouble getting the desired tach. picture proceed to the "Modified Condensation Section".
- 5] Set the signal pot for the desired speed verses input signal.
- 6] Check system for drift and re-balance if necessary.

TACH PICTORIAL SECTION

These tach pictures are typical of the responses obtained

It is important to observe the overall picture for mechanical problems plus the expanded view just before stopping

For the expanded view set the sweep speed at .1 sec/division and the vertical at a convenient display to see the corner

Use a step command such as from an on/off battery box

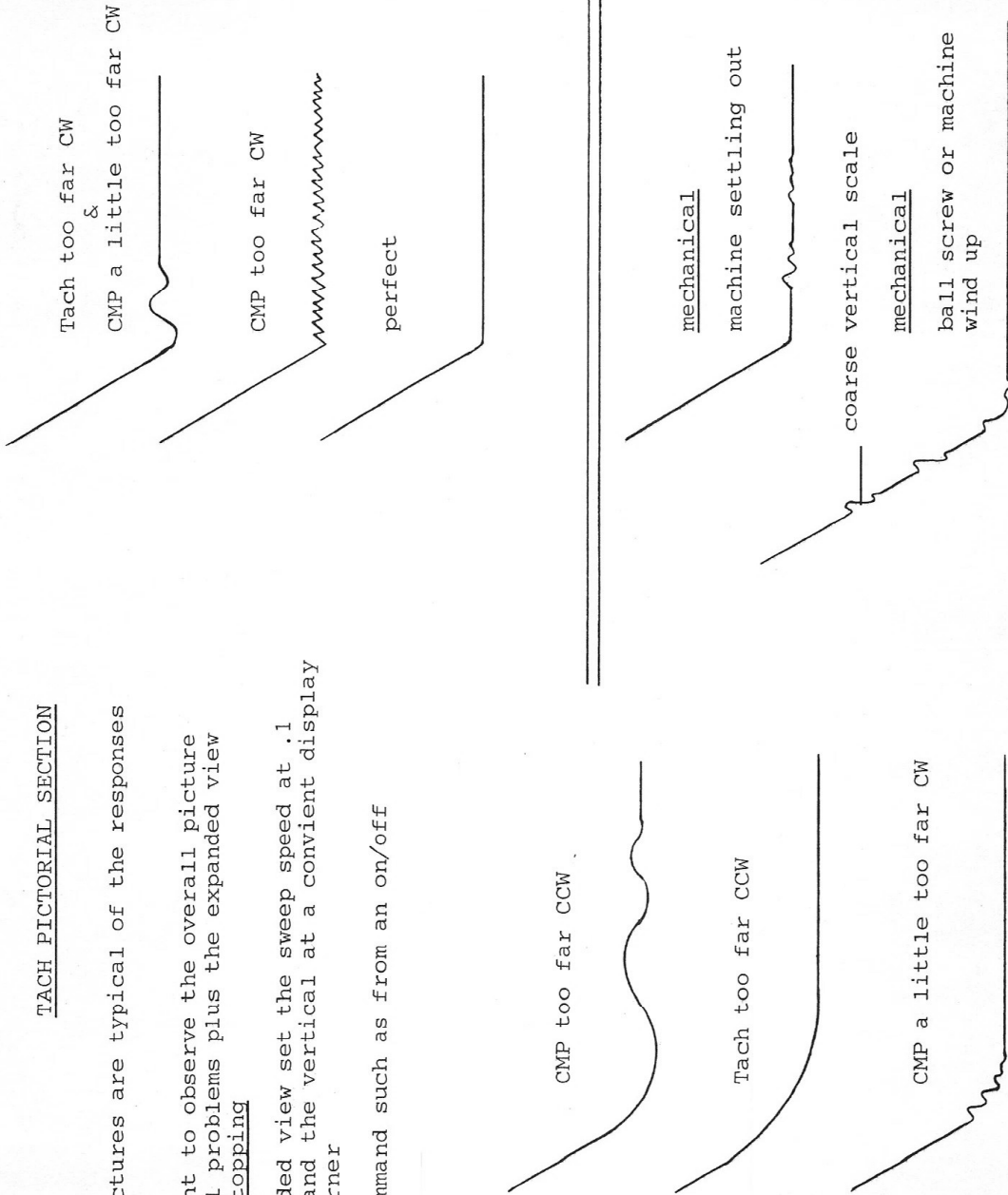

FIG. 3

TACH PICTORIAL SECTION

These tach pictures are typical of the responses obtained for closed position loops

These pictures are just before reaching final position - Just before stopping

Sweep speed at .1 sec/division and vertical at a convenient display to see the corner

Pictures assume the tach loop was set up correctly on battery box (open position loop) before closing position loop

(B)

Similar comments to curve A
Or

This could be correct picture for small following error systems (high gain in IPM/MIL)

(A)

Tach too far CCW
Or

Position loop gain too high (signal pot too far CW)
Or

System needs more power
Or
CNC needs more ramping

Note: When tach is adjusted CCW it will be necessary to adjust signal CCW to keep proper following area

Turn signal pot CW
Or
Tach pot CCW

Typical correct picture

MODIFIED COMPENSATION

Before modifying the compensation one should try to anticipate what is going to happen when a particular part value is changed.

IT IS ALSO NECESSARY TO TURN THE "CMP" POT FULLY CCW AND SLOWLY TURN IT CW AFTER ANY COMPENSATION PART VALUE IS CHANGED.

It is also a good idea before changing compensation values to check for mechanical backlash, misalignment, damaged couplings, lost motion, lead screw, or machine wind up.

- 1] UNABLE TO STOP THE SYSTEM FROM OSCILLATING AT HIGH FREQUENCY EVEN THOUGH THE "CMP" POT FULL CCW.

This type of system, due to ratio of the gains and break frequencies, just has too much bandwidth. It may be exciting a system resonance or the motor may be highly inductive, typically 9 MHY or greater.

Note: Motors of 2 and 3 inch diameters with torque constants K_T of 2 inlb/amp or greater, are typically high inductive motors.

If the system is unstable increase the value of capacitor " C_r " to .033 mfd and adjust the "CMP" pot fully CCW. It may also be necessary to decrease the tach gain by turning the tach pot CCW.

If system is still unstable increase the value of resistor " R_r " to 33K. Note: Add 100pfd in parallel with R_r when R_r is greater than 10K.

If the system oscillation is due to a mechanical resonance it may be necessary to add caps (C_6 , C_7) and (C_1) see below.

If the resonance is above 700CPS the total of C_6 & C_7 = 2.0 mfd and C_1 = .033 mfd.

Another idea is to decrease the value of C_1 to .022 mfd and not add C_6 , C_7 , C_17 . (please consult the factory for the explanation on this change).

- 2] IF THE MACHINE IS HAVING TROUBLE NULLING INTO POSITION, DUE TO NOT ENOUGH GAIN:

Increase C_t to .1 mfd and decrease R_t to 2K. and turn the tach pot CW to increase the tach feedback, which will increase the system gain.

You can also increase the forward loop gain of the Servo Amplifier by decreasing the value of R_{54} from 100 ohms to 10 ohms.

- 3] A HIGH INERTIA SYSTEM WHICH USUALLY HAS A LOW MECHANICAL BREAK FREQUENCY.

It may be necessary to increase C_t to .1 mfd and decrease R_t to 2K.

TROUBLE SHOOTING SECTION

If the amplifier does not turn-on, please read the comments below and read the "Protective Circuit Section" again.

If a fault indicator is "on" carefully look at which LED is lite.

And again look at the "Protective Section" for appropriate comment.

Other reasons for the drive not turning-on even though input power appears to be present.

Check limit switches, if using normally closed inputs, J1-14 & 15, must be at ground, for amplifier to operate.

Note: Factory shipped with jumpers in XY Position on board.

Measure the voltage on large bus cap if it is less than 30 volts the drive will not turn-on. Raise bus voltage DC.

Check to see if modules are receiving ± 15 volts, if not check fuse located on ± 15 volt power supply.

Check to see that motor leads are connected to appropriate terminals.

Motor runs away. Check and see if tach. voltage is really getting to the amplifier. A convient place to check is on TP6 with respect to TP1.

Nusiance tripping of the voltage LED. Check and see if the shunt regulator fuses are blown.

SHUNT REGULATOR (optional)

On some applications where several axis decelerate with a lot of inertia, at the same time, energy is pumped back into the main bus capacitor. This energy can cause the main bus capacitor to charge up to a voltage level beyond the capability of the amplifier.

The amplifier is protected against this over-voltage condition and will turn-off at 130 VDC. To avoid nuisance tripping, it may be necessary to have installed a shunt regulator to the DC Bus Capacitor. The shunt regulator turns on at 120 VDC. and shunts excessive voltage to ground thru voltage dropping resistors mounted on the amplifier chassis. The shunt regulator is protected against excessive dissipation by means of a fuse.

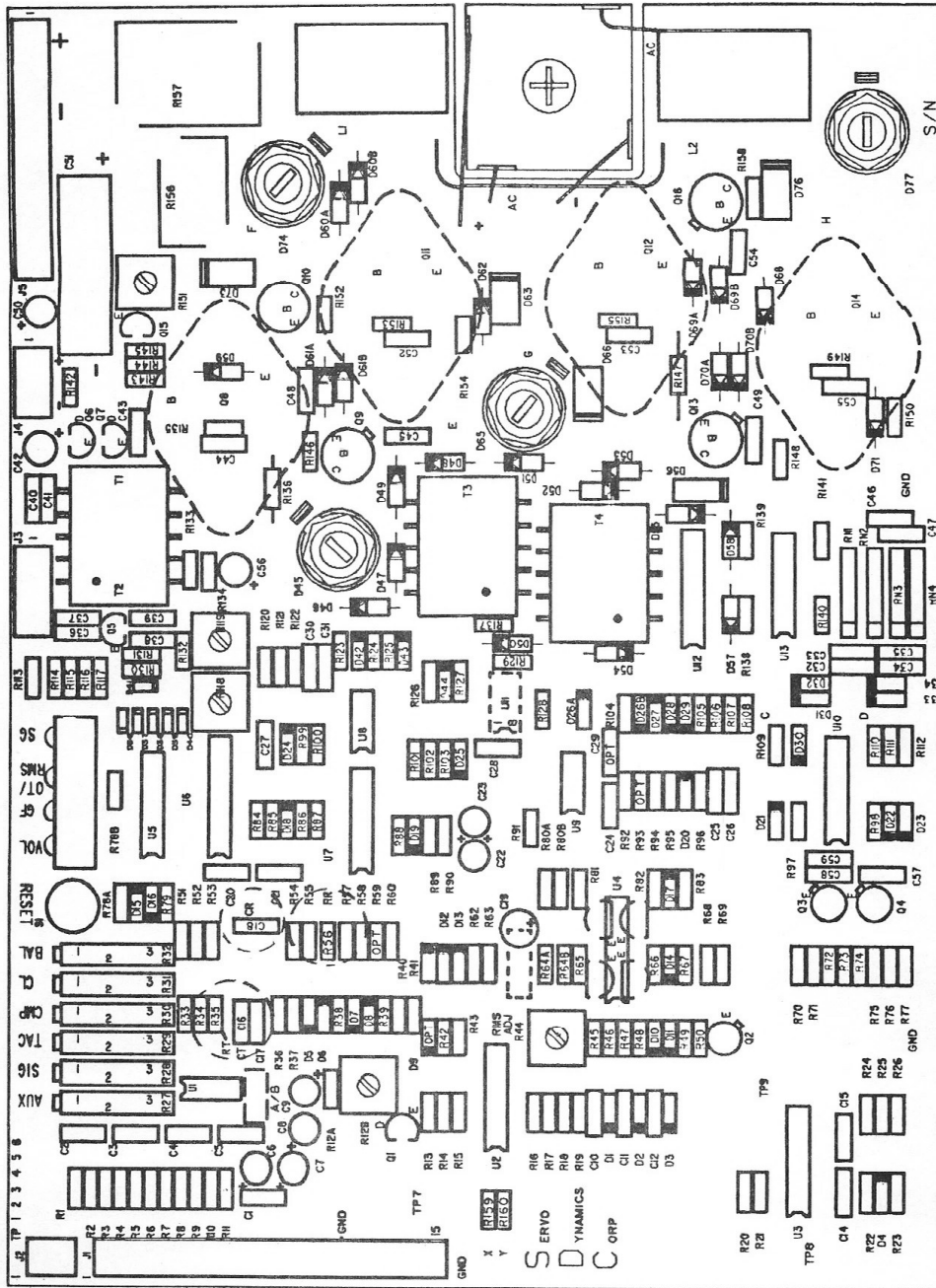

RECORD OF POTENTIOMETER SETTINGS
 USE OHMETER SET ON 20K OHM SCALE
 REMOVE INPUT CONNECTORS FROM J1 AND/OR J2

POTENTIOMETER	X AXIS	Y AXIS	Z AXIS	SPARE AXIS
AUXILIARY INPUT POTENTIOMETER R27 TP2 W.R.T. TP1				
SIGNAL INPUT POTENTIOMETER R28 TP3 W.R.T. TP1				
TACH. INPUT POTENTIOMETER R29 TP4 W.R.T. TP1				
* COMPENSATION (CMP) POTENTIOMETER R30 TP5 W.R.T. TP1				
CURRENT LIMIT (CL) POTENTIOMETER R31 J3-1 W.R.T. J3-3				
RMS LEVEL ADJUSTMENT POTENTIOMETER R44 MAX. CCW LOW LIMIT MAX. CW HIGH LIMIT				
NOTE: TP1 IS AT GROUND POTENTIAL. TP2-TP5 GO TO THE AFOREMENTION POTENTIOMETER WIPERS.				

*When adjusting the compensation pot. for the desired ohmic reading, start with the pot fully CW and turn CCW for the desired reading. Because of the pots. function in the circuit, the ohmic reading goes from a minimum to a maximum and back to a minimum, from one end of the adjustment to the other.

To assure correct resistance setting of compensation pot it is necessary to have the current limit pot fully CCW.

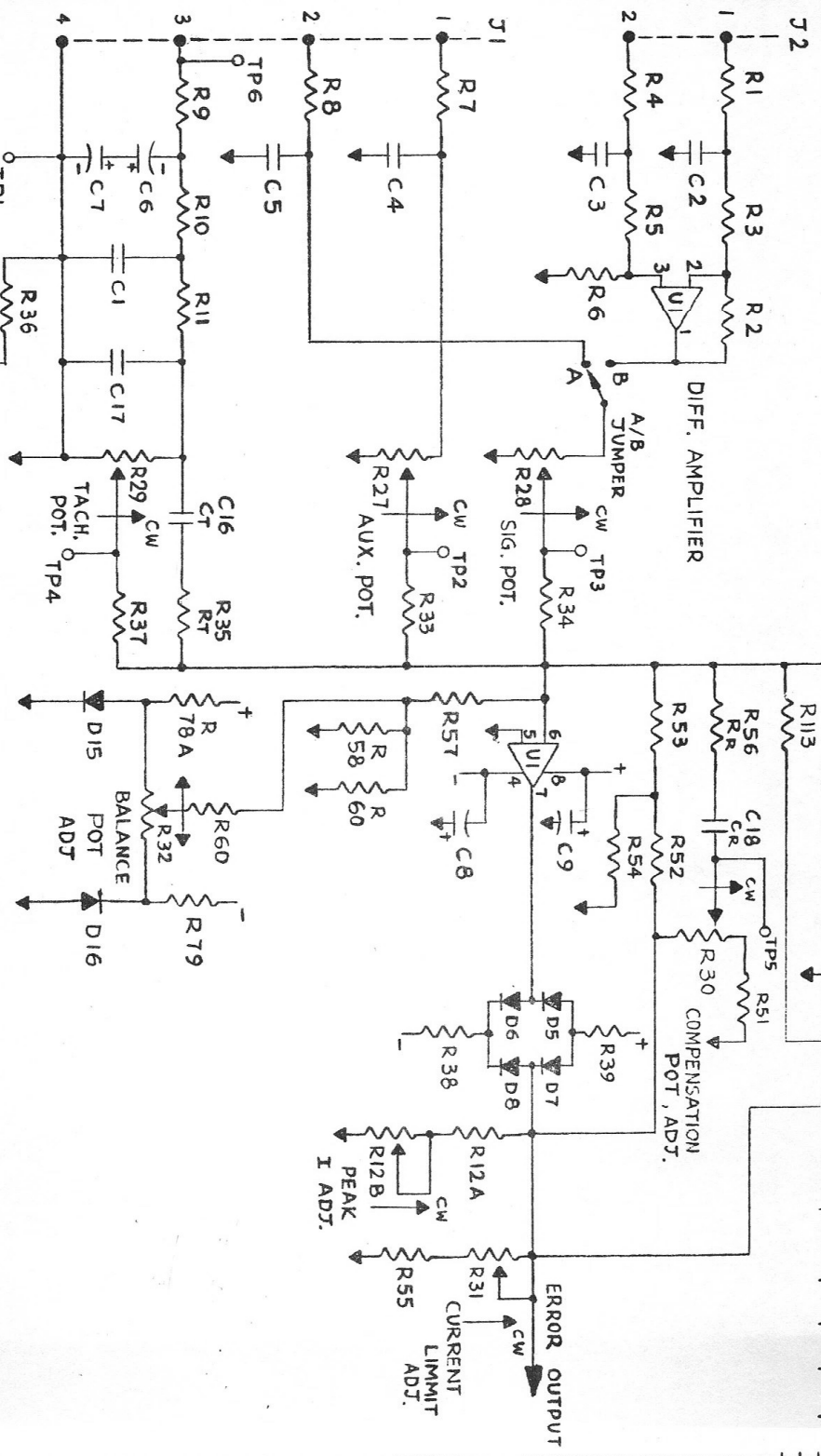

REV	DESCRIPTION	DRAWN	P.E.	CHK	APPR	DATE
1						
2						
3						
4						

CHASSIS THRU.
PEM. SCREW

UNLESS OTHERWISE SPECIFIED DIMENSIONS ARE IN INCHES BREAK ALL SHARP EDGES LEAVE ALL DECIMALS ANGLES: XXX.X XXX.XX XXX.XXX XXX.XXXX XXX.XXXXX		DRAWN CHKD ENGR	DATE 5/64
DO NOT SCALE THIS DRAWING THIS DRAWING IS THE PROPERTY OF SUMMING AMPLIFIER CO. IT IS TO BE KEPT IN THE OFFICE OF THE DRAWING ENGINEER AND NOT TO BE REPRODUCED OR COPIED IN ANY MANNER WITHOUT THE WRITTEN PERMISSION OF SUMMING AMPLIFIER CO.		APPR	
TITLE SERVO DYNAMICS CORP.		APPROVED	
SIZE	SCALE	SIZE	SCALE
1203			

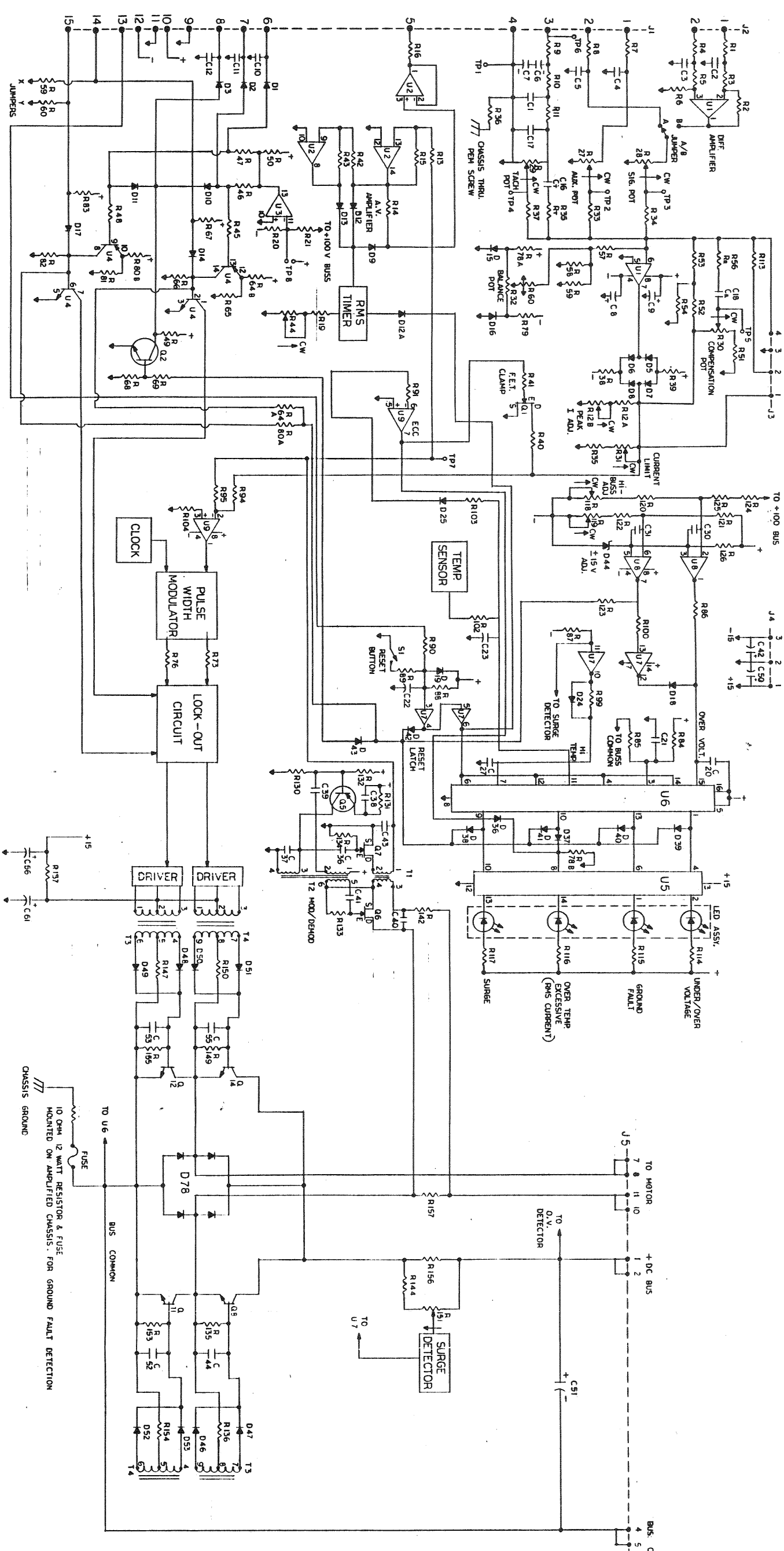

10 OHM 1/2 WATT RESISTOR & FUSE MOUNTED ON AMPLIFIED CHASSIS. FOR GROUND FAULT DETECTION

SERVO DYNAMICS CORP.	
TITLE: SIMPLIFIED SCHEMATIC	
SD1015/SD1525	
SIZE: 5/8" X 11"	NUMBER: 1202
DATE: 1/78	REV: A
DESIGNED BY: JAMES W. BROWN	CHECKED BY: JAMES W. BROWN
APP'D BY: JAMES W. BROWN	DATE: 1/78
SCALE: 1:1	SHEET: 2 OF 2

APPENDIX

VARIOUS TACH GRADIENTS

As a general statement the amplifiers are set up to work with the tach pot in mid position.

In order to keep the tach pot in mid position a tach divider is recommended (due to various tach gradients).

If a higher voltage tach is used and the tach divider is not used then the system might not attain full speed.

VOLTAGE DIVIDER IN TACH CIRCUIT

TACH GRADIENT (V/1000 RPM)	IN C17 SLOT INSTALL THE RESISTOR LISTED
31.5V	2.4K
20V	3.9K
15V	6.8K
12.5V	9.1K
7V	NONE

39V
50V

2.0K
1.5K



SERVO DYNAMICS

21541 D Nordhoff St., Chatsworth, CA 91311
(818) 700-8600 • FAX (818) 718-6719

APPLICATION NOTES

PROCEDURE FOR SETTING RMS CURRENT
BY RMS (R44) POT

- 1] Disconnect all power to circuit board.
- 2] Connect a digital meter (set on 20K OHM scale) to left side of R19 with respect to ground.
- 3] Set to values shown below for desired RMS current.

<u>RMS CURRENT</u>	<u>*OHMIC READING</u>
15 Amps	9.4K
12.5 Amps	8.2K
10 Amps	6.3K
7.5 Amps	4.5K
5 Amps	3.0K

*As measured from left side of R19 with respect to ground.



SERVO DYNAMICS CORP.
21541D NORDHOFF ST.
CHATSWORTH, CA 91311

APPLICATION NOTE

SD SERIES

SEPARATE CHASSIS' OF THE SAME BUS VOLTAGE RATING OPERATING OFF ONE
COMMON TRANSFORMER

In order to prevent nuisance tripping of the ground fault detector on various chassis due to the ground reference changing when power is first turned on.

It is necessary to connect the negative of the bus capacitors on each chassis together with a #10 gauge wire.

It is also necessary to connect each of the chassis' plates together with a #10 gauge wire.

APPLICATION NOTE

SD AND SDF SERIES

USE OF NORMALLY CLOSED LIMIT SWITCHES J1, PINS 14 AND 15

When using J1, Pins 14 and 15, which are the normally closed limit switch inputs, it is suggested that the return line be the -15 volt (J1, Pin 12) with a 1K buffer resistor in series with the -15 volt pin, rather than to Pin 9 (common).

The reason for this is to provide greater noise immunity on J1, Pins 14 and 15.

Noise getting into J1, Pins 14 and 15 will randomly turn the amplifier on and off and make the motor run in an erratic manner. The 1K buffer is used to protect the -15 volt supply from burn out if the limit switch wires become shorted to ground.

APPLICATION NOTES

SD SERIES

Normally Closed Limit Switch (J1, Pins 14 & 15)

When these inputs are held at ground the drive is inhibited. However the threshold to release the inhibit is +1.2 volts. There are times when the limit switch wires are subject to the switching noise produced by the amplifier then the motor will run in an erratic manner because the drive is being turned on and off by the voltage induced on the limit switch inputs which is randomly greater than +1.2 volts.

In order to reduce the sensitivity of Pins 14 & 15 the return wire from the limits (which normally would go to J1, Pin 11 (common)) can be connected to J1, Pin 12 (-15 volts) with a 1K buffer resistor in series with the limit switch return and the -15 volts Pin 12.

The 1K buffer resistor is used as a safety factor, in case a limit switch line gets shorted to ground. The 1K limits the current delivered by the -15 volt power supply so the power supply does not burn out.

Connecting Pins 14 & 15 to -15 volts increases the trip level threshold to 16.5 volts thus increasing the signal to noise ratio.

Threshold Levels

J1, Pins 6,7,8,14, & 15 inputs have TTL Threshold. However these Pins are connected internally to +15 volts in the amplifier. Not to +5 volts which is usually termed TTL.

Low to Enable

In the SD series if one wanted to pull a line low to have the amplifier enabled one could connect J1, Pins 14 & 15 (N.C. limits) together and then connect to common.

J1 Pin 8

This Pin can be pulled up to an external +24 volts provided D3 and R49 are removed and a 1K resistor is installed in series with Pin 8.

7/19/95



SERVO DYNAMICS
21541 D NORDHOFF STREET
CHATSWORTH, CA 91311

APPLICATION NOTE
SD POWER AMP DISCUSSION

A) TENSION (TORQUE) CONTROL SYSTEMS

OR

B) SYSTEMS THAT DO NOT USE TACHOMETER FEEDBACK

Usually require a power stage as part of the control system, that provides a proportional output relative to the command.

HOW TO CONVERT A STANDARD SD1525-10 CURRENT MODE AMPLIFIER MODULE INTO A POWER STAGE WHICH HAS THE APPROPRIATE LINEAR AND PROPORTIONAL GAIN.

- 1) Install a jumper link at J3 between Pins 1 and 2. (This reduces the gain of front end op-amp so that it has a max. gain of 2).
- 2) Turn any unused signal (tach) inputs fully "CCW"
- 3) Turn compensation pot. fully "CW".
- 4) Adjust signal pot. for appropriate scaling of the power amplifier to have linear and proportional gain.

Shown below is a table listing the typical signal pot setting for a 10 volt command which will give the desired peak current and keep the amplifier in its linear region and have proportional gain.

SIGNAL POT TYPICAL SETTING *	PEAK OUTPUT CURRENT
(DIFFERENTIAL)	
6.35K	25 AMPS
5.17K	20 AMPS
3.87K	15 AMPS
2.62K	10 AMPS
1.32K	5 AMPS

* Signal pot settings are measured with an ohm meter set on the 20k scale and with the J1/J2 connector removed. TP1 (Common) with respect to TP3 (signal pot wiper).